

NOTES:

1. Concrete Strength: 5000 psi at 28 days.
2. Reinforcement: ASTM A-615 Grade 60.
3. Pins Available: #5 Rebar @ 18" Long.
4. Weight: 170 lbs.

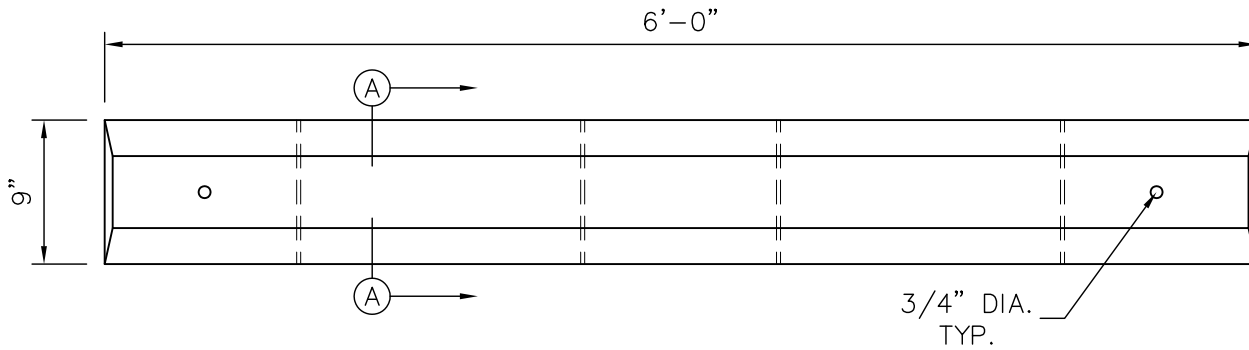

PLAN VIEW

SCALE: 1" = 1'-0"

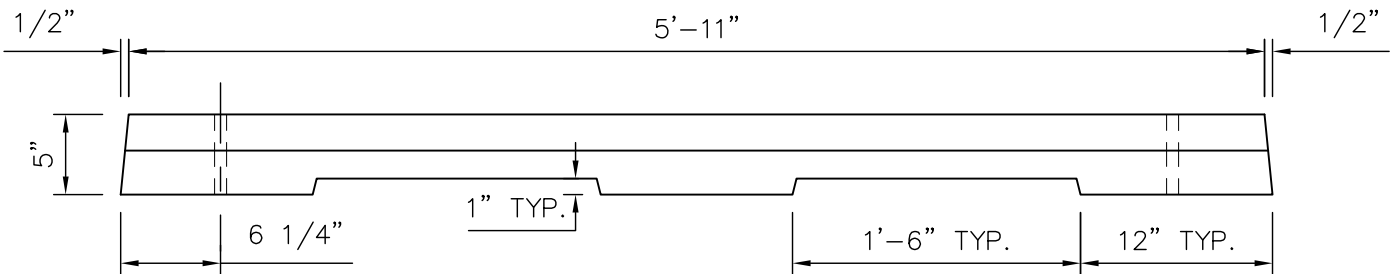

FRONT VIEW

SCALE: 1" = 1'-0"

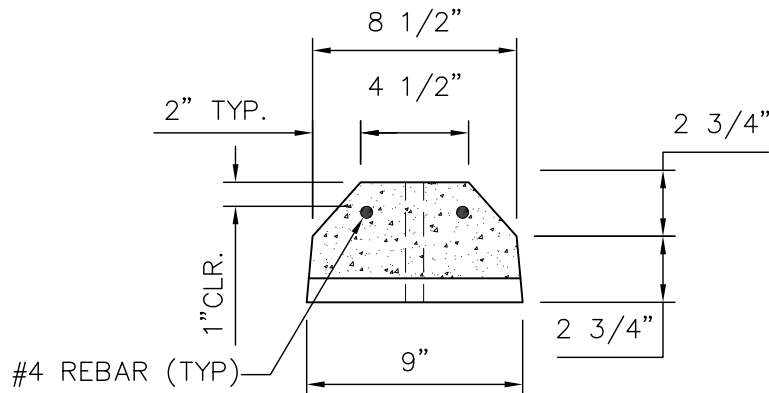

SECTION VIEW A-A

SCALE: 1 1/2" = 1'-0"



1-800-638-6884
www.gillespieprecast.com

6' Parking Bumper

DRAWN BY: JHP
SCALE: AS NOTED

DWG.: 1 of 1
DATE: 11/3/15